

# *US HYDRAULICS*

US HYDRAULICS Established in 1998 A Technologically & Professionally.

We are one of the leading players in the design, manufacturing and supply of the high precision, consistent and productive fixture.

Our experienced staff with strong technical background, working at all level in the organizational structure with a never say die attitude has been driving the entire set up.

Our manufacturing facility is equipped with full-fledged equipments, capable of making most intricate and complex fixture suitable for hydraulic fixture

Pneumatic fixture manual fixture jig & fixture all types of tool room works.

With our most competent group of engineers, we turn our customers dream in to reality with the backup of most modern technology

## **WE ARE MANUFACTURER SCOPE**

- Hydraulic fixture.
- Pneumatic fixture.
- Manual fixture.
- Manual jig & fixture.
- Relation gauge.
- Special purpose machines.
- All Type of Tool Room Works
- Hydraulic power unit
- All type of production system(cradle units)
- Prototype component machining
- Mass production

## **OUR PRESTIGIOUS CUSTOMERS**

- AMTEK AUTO LTD.
- EXON MACHINES PVT. LTD.
- KALYANI TECHNOFORE LTD CHAKAN
- KALYANI TECHNOFORGE LIMITED KHED
- KALYNI TECHNOFORGE LIMITED MUNDHAWA
- LINAMAR INDIA PVT.LTD (DEWAS)
- PITTI ENGINEERING LIMITED (HYDRABAD)
- TRINITY AUTO COMPONENT LTD
- INLEAD TECHNOLOGY LLP
- KCMi BHART FORGE LTD
- EASTERN ALLOYS PVT.LTD (ODISHA)
- PUNE FORGE PVT.LTD
- UMANG ENGINEERS
- ARATE ENGINEERING PVT.LTD
- SHREENATH MATEL PVT.LTD
- THAR MACHINING PVT.LTD
- 3MT ENTERPRISES PVT.LTD
- KRANTI INDUSTRIES LTD
- S&T MACHINERY LTD (TAMILNADU)
- OKAY FERN PVT.LTD (NASHIK)
- VICTORY PRECISION PVT.LTD
- FORBES MARSHALL PVT.LTD
- KRONE MARSHALL PVT.LTD
- YASH INDUSTRIES (PANT NAGER)
- SINGLA FORGING LTD(PANT NAGER)

- VIJAYALAXMI GEAR PVT.LTD(DHARWAD KARNATAKA)
- YASH INDUSTRIES (KOLHAPUR)
- KORES INDIA LIMITED
- OMKAR MACHINING
- SV ENTERPRISES
- PRADEEP MATEL LIMITED
- ETAPLAST PVT.LTD (MUMBAI)
- ETAPLAST PVT.LTD (CHAKAN )
- BALAJI ENGINEERING (MUMBAI)
- ADROID AUTO COMPONENT PVT.LTD
- AVTECH LIMITED (PRITHAMPUR MP) N  
**NYOSYM LIMITED**

**SOME OF PROJECTES HANDLE BY OUR TEAM (2018-2022)**

- 1109,FRONT AXLE BEAM VMC FIXTURE .
- 709,909 KNUCKEL HYD. FIXTURE PROJECT.
- 410 STEERING KNUCKEL HYD. FIXTURE PROJECT.
- 16T STEERING KNUCKEL FIXTURE PROJECT.
- 709.909.FRONT AXLE BEAM HYD. FIXTURE PROJECT.
- YOKE KING PIN HYD FIXTURE PROJECT
- JL YOKE HYD FIXTURE PROJRCT
- SHIFTER FORK VMC HYDRAULIC FIXTURE

- SPRING SIDE HOUSING VMC ROTARY HYDRAULIC FIXTURE
- STEERING ARM VMC ROTARY FIXTURE
- YOKE 760 ROTARY HYDRAULIC FIXTURE
- LEANAMER OUTPUT GEAR DRILLING HYD FIXTURE
- TURBINE HOUSING HYDRAULIC FIXTURE PROJECT
- PADMINI ETV HOUSING HYD FIXTURE PROJECT
- STAR BAR VMC HYDRAULIC FIXTURE
- CYL BLOCK VMC HYDRAULIC FIXTURE
- MIRROR VMC HYD FIXTURE
- CAM SHAFT FACING CENTRING FIXTURE
- SPRING SIDE VMC ROTARY HYD FIXTURE PROJECT
- BLOWER HOUSING HMC FIXTURE PROJECT
- HEAD 500 HEAD 300 HEAD 180 FULL FINISH PROJECT
- ROTTER POLE HMC FIXTURE PROJECT
- P708 SLIP YOKE PROJECT (DANA SPICER)
- P708 DIFF. CASE PROJECT(DANA SICER)
- DIFF. CASE (MARUTI)
- E VALVE BODY
- PISTON VALVE BODY
- KTM CYLINDER HEAD
- KTM FOOT PEG
- BEARING CAP (JAIHIND)
- BEARING SUPPORT
- CYL BLOCK 6 CYLINDER(ISSUZU)
- E-VALVE BODY
- TUBE FLANGE 721 731 730
- KNUCKLE
- CARRIER HHOUSING MTR NINE

# !IN HOUSE MACHINE SHOP!

MACHINING TYPE	SIZE
VMC BFW BMV50 TC24 -1 NOS	TRAVEL-(800X510X510)
MILLING MACHINEG DUFOUR -2Nos	TRAVEL-(1000X300 X320)
SURFACEGRINDING (JACOBSON) -1Nos	TRAVEL-(750X350 X320 )
LATHE MACHINE -1 Nos	7 FT
◇M1TR-1 Nos	TRAVEL-(1200X300 X300)
CMM-ZEISS SPECTRUM PLUS-1Nos	TRAVEL-(700X700X600)

## **MACHINING TYPE**

## **SIZE**

- **WIRE CUT**

**1000 X400 X400**

- **EDM**

**800 X600 X600**

- **ROTARY GRINDING**

**2000 X800 X800**

- **ENGRAVING**

**600 X300 X200**

- **CYLINDRICAL GRINDING**

**OD200 XID150 X1000**

- **VACUUM HEAT TREATMENT**

**UPTO 1200KG**

- **PLANO MILLING MACHINE**

**3000 X1000 X1000**

## **CONTACTS**

- MR. PATHAN (DIRECTOR)

Contact: - 9922629237

9890277737

EMAIL-us.hydraulics2018@gmail.com

WEB-www.ushydraulicsfixture.com

### ADDRESS

S-BLOCK S-234/9 NEAR INDRAYA CORNER

PCNTDA, BHOSARI,

PUNE- 411 026.

## **COMPANY PROFILE**

**Establishment :Year - 2018**

**No. of Units : One**

**Business : Manufacturer of Hyd Vmc Hmc  
Fixtures Hyd Rotary Fixtures 4th  
axis Cradle Units Jig & SPM'Conveyor**

**Location : S-BLOCK S-234/9 MIDC BHOSARI  
PUNE-411026**

**Our Bank : IDBI BANK.**

**GST No. : 27EPPPP0574E1ZJ**

**Pan No. :EPPPP0574E**

**Company Policy : Continuous improvement in quality**

**Customers Satisfaction.**



(Amended)



Government of India  
Form GST REG-06  
(See Rule 10(1))

Registration Certificate

Registration Number : 27EPPP0574E1ZJ

1.	Legal Name	PATHAN SALEHA KAUSAR UMAR KHAN			
2.	Trade Name, if any	U S HYDRAULICS			
3.	Additional trade names, if any				
4.	Constitution of Business	Proprietorship			
5.	Address of Principal Place of Business	PLOT NO- S-234/9, S BLOCK BHOSARI MIDC, Indrayani Nagar Road, Bhosari, Pimpri Chinchwad, Pune, Maharashtra, 411025			
6.	Date of Liability				
7.	Date of Validity	From	15/04/2019	To	Not Applicable
8.	Type of Registration	Regular			
9.	Particulars of Approving				
Signature		Signature Not Verified Digitally signed by 27EPPP0574E1ZJ ANU SERVICE TAX NETWORK OF Date: 2023.08.05 12:28:54 IST			
Name					
Designation					
Jurisdictional Office					
Date of Issue of Certificate		05/08/2023			
Note: The registration certificate is required to be prominently displayed at all places of Business/Office(s) in the State.					

This is a system generated digitally signed Registration Certificate issued based on the deemed approval of application on 05/08/2023.





## *Certificate of Registration*

This is to certify that

### **U S HYDRAULICS**

**S-234/9,S-BLOCK NEAR INDRAYANI CORNER PCNTDA BHOSARI,  
PUNE – 411026, INDIA**

has been independently assessed by QRO  
and is compliant with the requirement of:

**ISO 9001:2015**

### **Quality Management System**

For the following scope of activities:

**HYDRAULIC FIXTURE, PNEUMATIC FIXTURE, MANUAL FIXTURE, MANUAL JIG  
& FIXTURE, RELATION GAUGE.SPECIAL PURPOSE MACHINES. ALL TYPE OF  
VMC, CNC PRECISION WORK.**

Date of initial registration: 26th May 2021

Recertification due: 25th May 2024

Date of this certificate: 11th May 2023

Certificate Expiry: 25th May 2024

**Certificate Number: 305021052606Q**



Head of Certification

Validity of this certificate is subject to annual surveillance audits to be done successfully on or before 90 days from date of the audit.  
(In case surveillance audit is not allowed to be conducted, this certificate shall be suspended / withdrawn.)

The Validity of this certificate can be verified at [www.grocert.org](http://www.grocert.org)

This certificate of registration remains the property of QRO Certification LLP, and shall be returned immediately upon request.

India Office : QRO Certification LLP

142, 1st Phase, Anar Enclave, Near Panchin Vihar West Metro Station, Delhi-110063, (INDIA)

Website : [www.grocert.org](http://www.grocert.org), E-mail : [info@grocert.org](mailto:info@grocert.org)



# CERTIFICATE



ZERTIFIKAT | CERTIFICATE | CERTIFICAT | CERTIFICADO | CERTIFIKAT | 証明書 | 인증서

## Management system as per EN ISO 9001:2015

In accordance with TÜV AUSTRIA procedures, it is hereby certified that

### US HYDRAULICS

**S-Block, S-234/9, Near Indrayani Corner, PCNTDA,  
Bhosari, Pune - 411026, Maharashtra, India**

applies a management system in line with the above standard for the following scope

**Manufacturing and Supply of Machined Parts, Jigs and Hydraulic Fixtures,  
Hydraulic Elements, SPM**

Certificate Registration No. 20100233017918

Valid until: 2026-10-08  
Initial certification: 2023-10-09

Certification Body  
at TÜV AUSTRIA GMBH

Vienna, 2023-10-09

This certification was conducted in accordance with TÜV AUSTRIA auditing and certification procedures and is subject to regular surveillance audits.  
TÜV AUSTRIA GMBH Deutschstraße 10 A-1230 Wien [www.tuv.at](http://www.tuv.at)







सत्यमेव जयते

Government of India / भारत सरकार

Ministry of Commerce and Industry / वाणिज्य और उद्योग मंत्रालय

Directorate General of Foreign Trade / विदेश व्यापार महानिदेशालय

Office of the Joint Director General of Foreign Trade, Pune / संयुक्त महानिदेशक, विदेश व्यापार का कार्यालय, पुणे

C Block, PMT Commerical, Complex PB NO.1623, PUNE, MAHARASHTRA, 411042 / सी ब्लॉक, पीएमटी

कमर्शियल, कॉम्प्लेक्स पीबी नंबर 1623, पुणे, पुणे, महाराष्ट्र, 411042

Importer-Exporter Code

This is to certify that U S HYDRAULICS is issued an Importer-Exporter Code (IEC) EPPPP0574E with details as follows -

IEC	EPPPP0574E
स्थाई खाता सं.(पेन) /PAN	EPPPP0574E
फर्म का नाम/Firm Name	U S HYDRAULICS
निगम की प्रकृति /Nature of Concern	Proprietorship
जारी करने की तारीख/Date of Issue	23/03/2023
पता/Registered Address	GAT NO 24, SAMRAJ INDUSTRIAL ESTATE,S BLOCK, BHOSARI MIDC, NEAR INDRAYANI CORNER, BHOSARI,HAVELI,, Pune, PUNE, MAHARASHTRA, 411026
धारक का नाम / Name of the Signatory	SALEHA KAUSAR UMAR KHAN PATHAN
Director / Partner Details	Refer online at <a href="https://dgft.gov.in">https://dgft.gov.in</a> or scan the QR Code
शाखा/इकाई /Branch Details	Refer online at <a href="https://dgft.gov.in">https://dgft.gov.in</a> or scan the QR Code

Last Modified : 23/03/2023

File Number : PUNIECPAPPLY00020440AM23



Note : This is a system-generated certificate. Authenticity / Updated details of the IEC can be checked at official DGFT website <https://dgft.gov.in> by entering the IEC and Firm Name under Services > View Any IEC Details. You can also authenticate the certificate by scanning the QR code.



# Authorized Stockist Certificate

This is to certify that

**US Hydraulics, Pune**

Is our Authorized Stockist for our all range of Products.

Valid Till 31<sup>st</sup> March 2024



Mr. Karan Gudale

(Sr. Sales Engineer-Maharashtra)

Scanned with OKEN Scanner



**! US HYDRAULICS !**



**MACHINE NAME: BROTHER**

**FIXTURE NAME: 200 CRADLE UNIT**

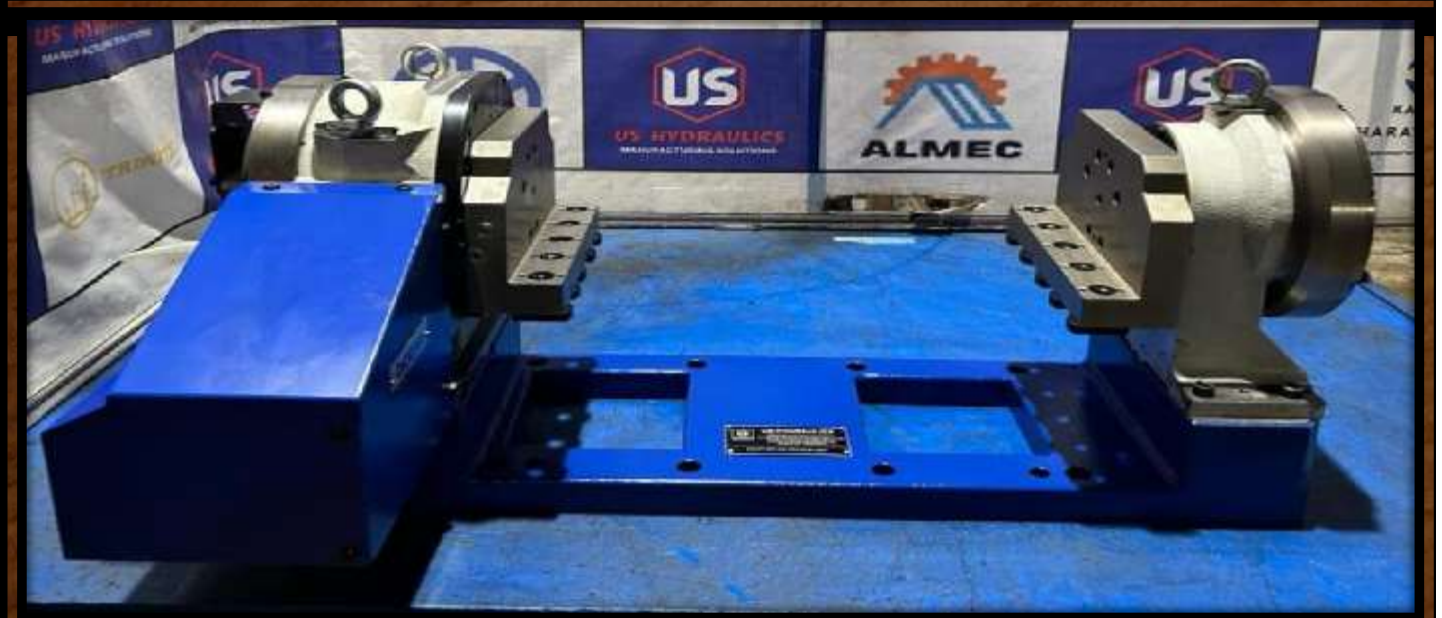
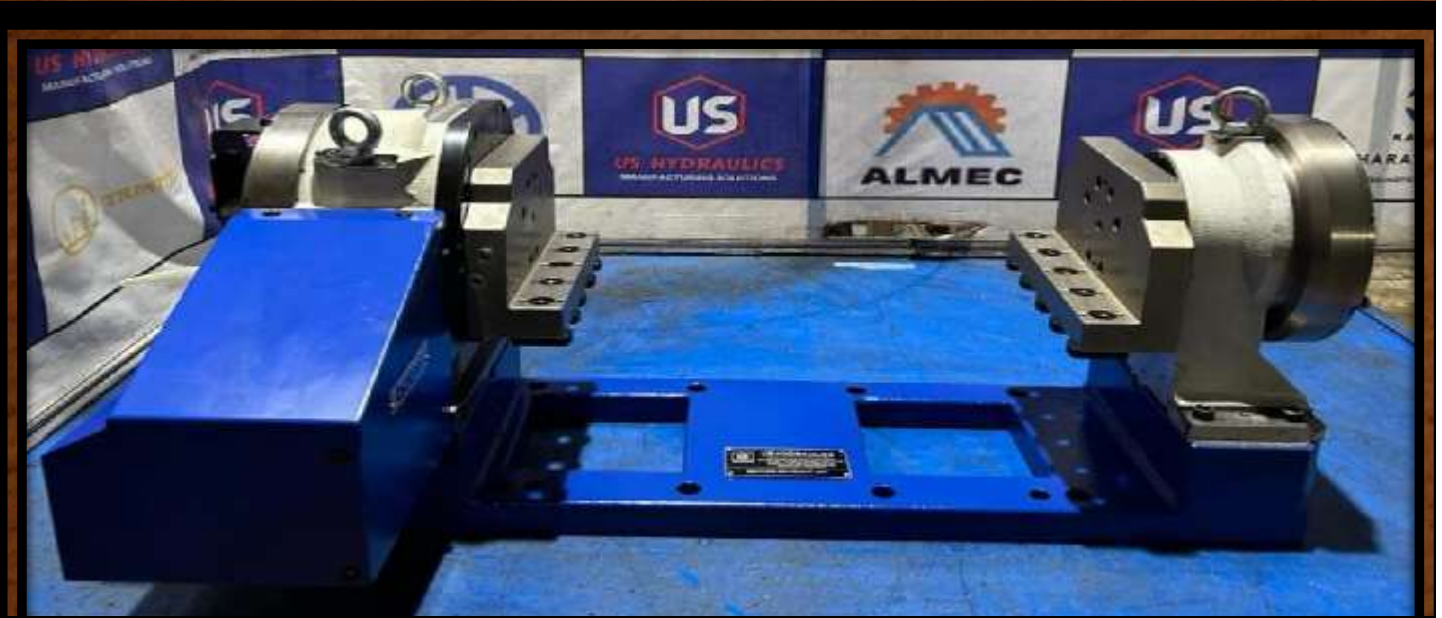



**! US HYDRAULICS !**



**MACHINE NAME: MAKINO A81**

**FIXTURE NAME : OP-10 HMC HYD FIXTURE FOR SML CYL  
BLOCK**





**! US HYDRAULICS !**



**MACHINE NAME : MAKINO A81**

**FIXTURE NAME : OP-10 HMC HYD FIXTURE FOR SML CYL  
BLOCK**





**! US HYDRAULICS !**



**MACHINE NAME : MAKINO A81**

**FIXTURE NAME : OP-20 HMC HYD FIXTURE FOR SML CYL  
BLOCK**





**! US HYDRAULICS !**



**MACHINE NAME : MAKINO A-81**

**FIXTURE NAME : OP-30 HMC HYD FIXTURE FOR SML CYL  
BLOCK**





**! US HYDRAULICS !**



**MACHINE NAME : MAKINO A-81**

**FIXTURE NAME : OP-40 HMC HYD FIXTURE FOR SML CYL  
BLOCK**





**! US HYDRAULICS !**



**MACHINE NAME : MAKINOA-81**

**FIXTURE NAME : HMC HYD FIXTURE FOR SML CYL BLOCK**





**! US HYDRAULICS !**



**MACHINE NAME : AMS 450**

**FIXTURE NAME : ALL OPERATIONS VMC ROTARY HYD  
FIXTURE FOR CAM SHAFT (ROYAL ENFIELD) WITH CRADLE**



**! US HYDRAULICS !**



**MACHINE NAME : HMC BFW -800X800**

**FIXTURE NAME : ALL OPERATION FINISH HMC HYD FIXTURE  
FOR BLOWER HOUSING**

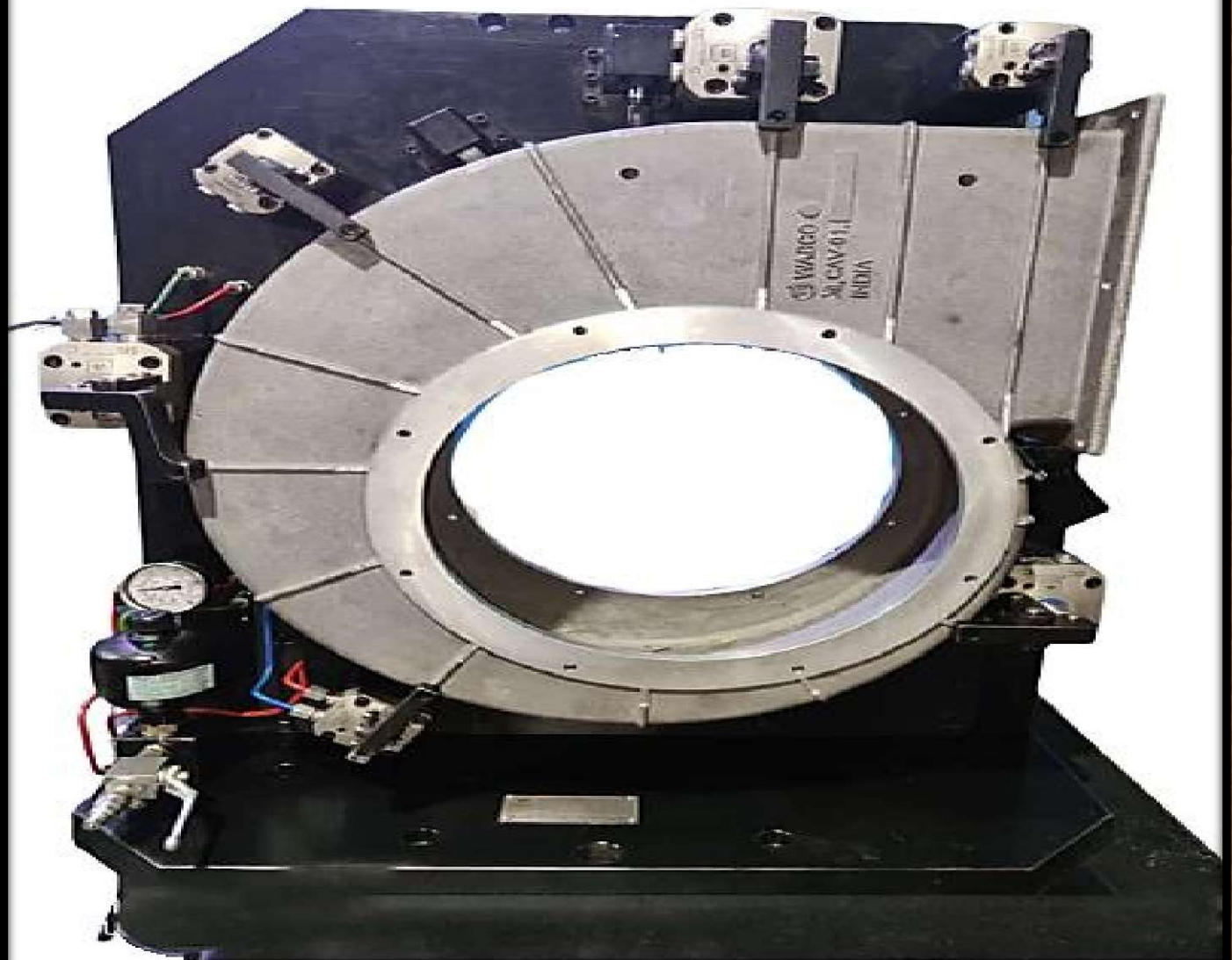



**! US HYDRAULICS !**



**MACHINE NAME : HMC BFW 800X800**

**FIXTURE NAME : ALL OPERATIONS HMC HYDRAULIC  
FIXTURE FOR BLOWER HOUSING**

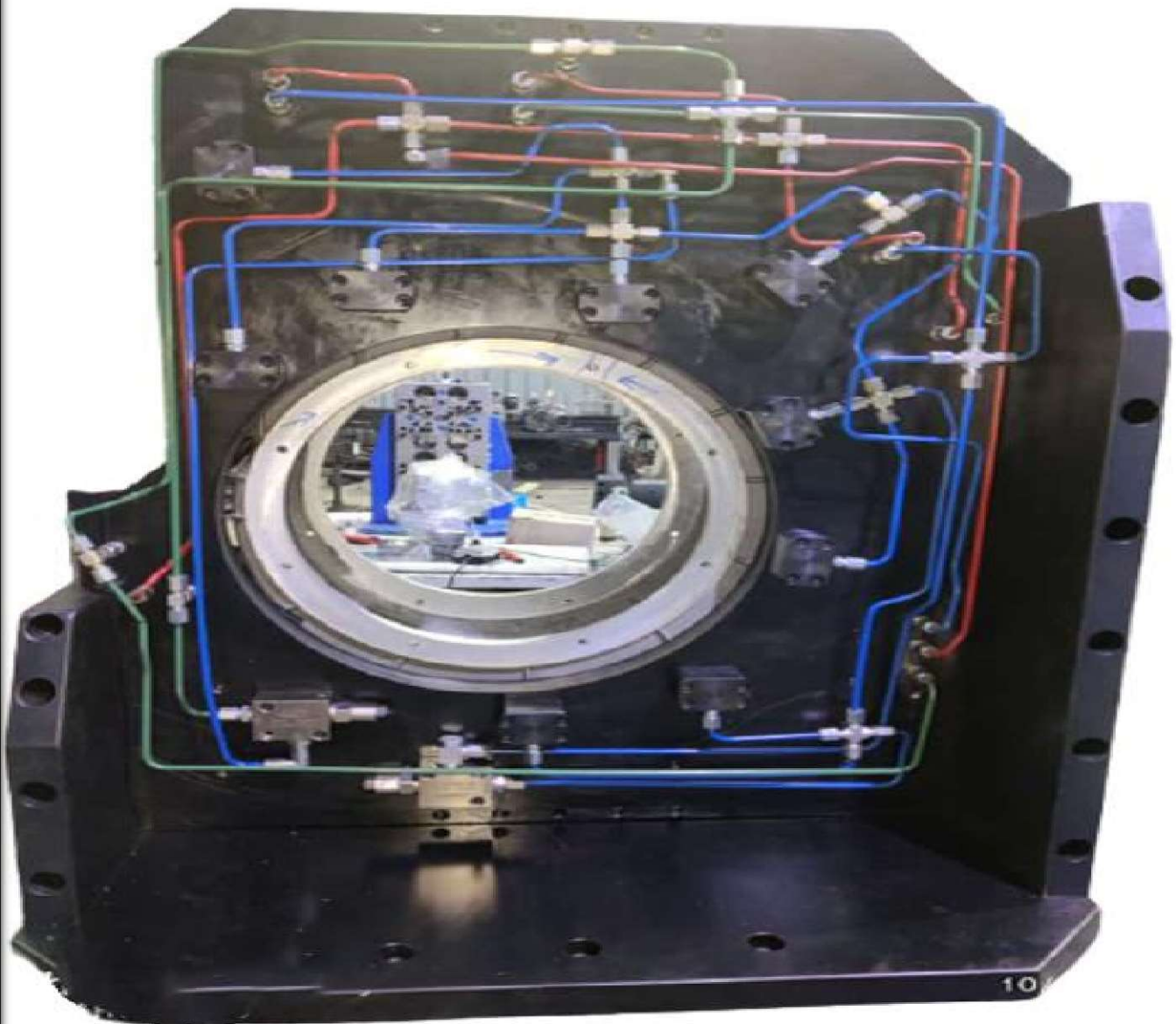



**! US HYDRAULICS !**



**MACHINE NAME : AMS 450**

**FIXTURE NAME : OP-10 VMC HYD FIXTURE FOR P-702 SLIP  
YOKE**

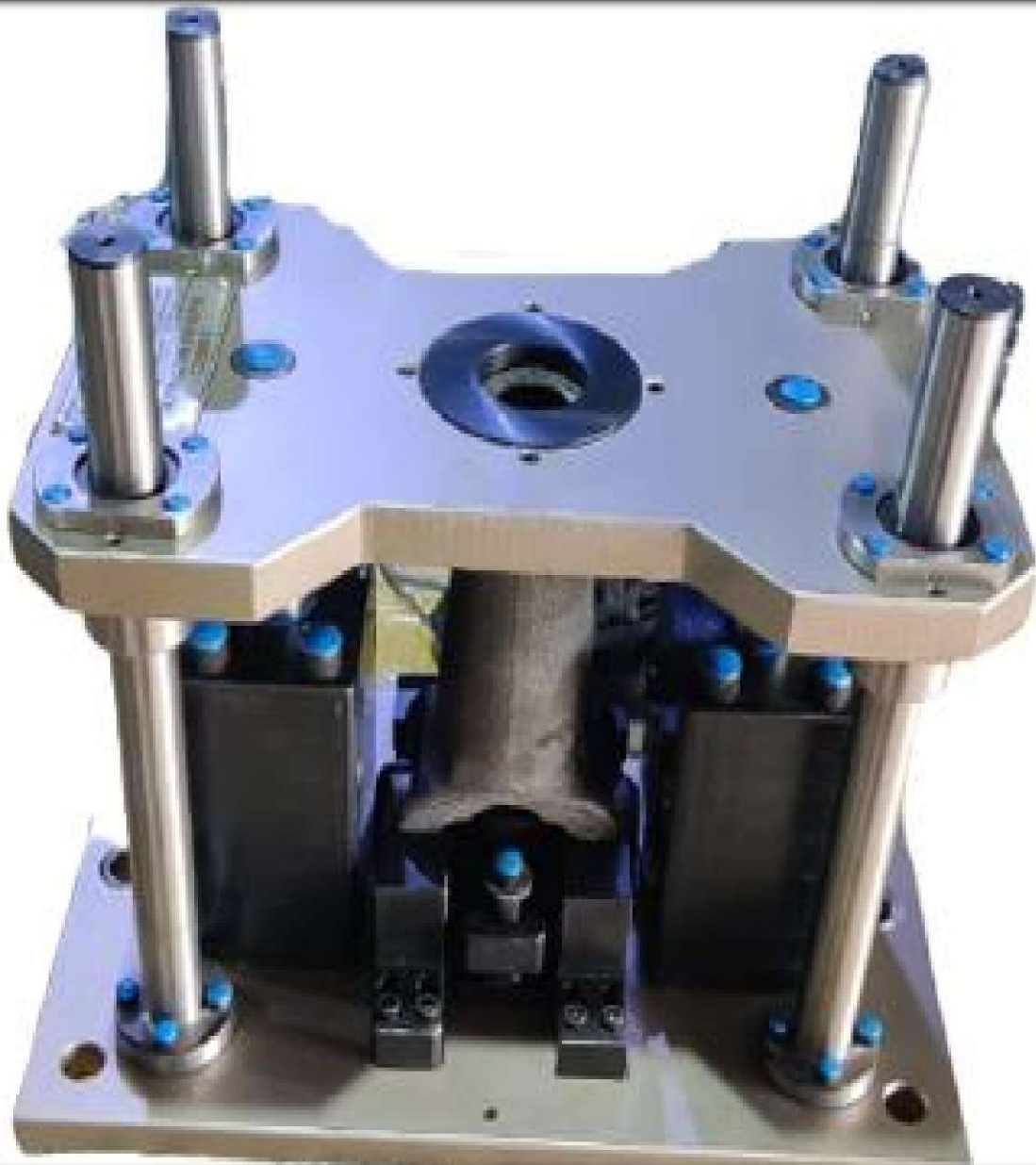

**! US HYDRAULICS !**



**MACHINE NAME : AMS 450 4<sup>TH</sup> AXIS**

**FIXTURE NAME : OP-40 VMC ROTARY HYD FIXTURE FOR P-702 SLIP YOKE**

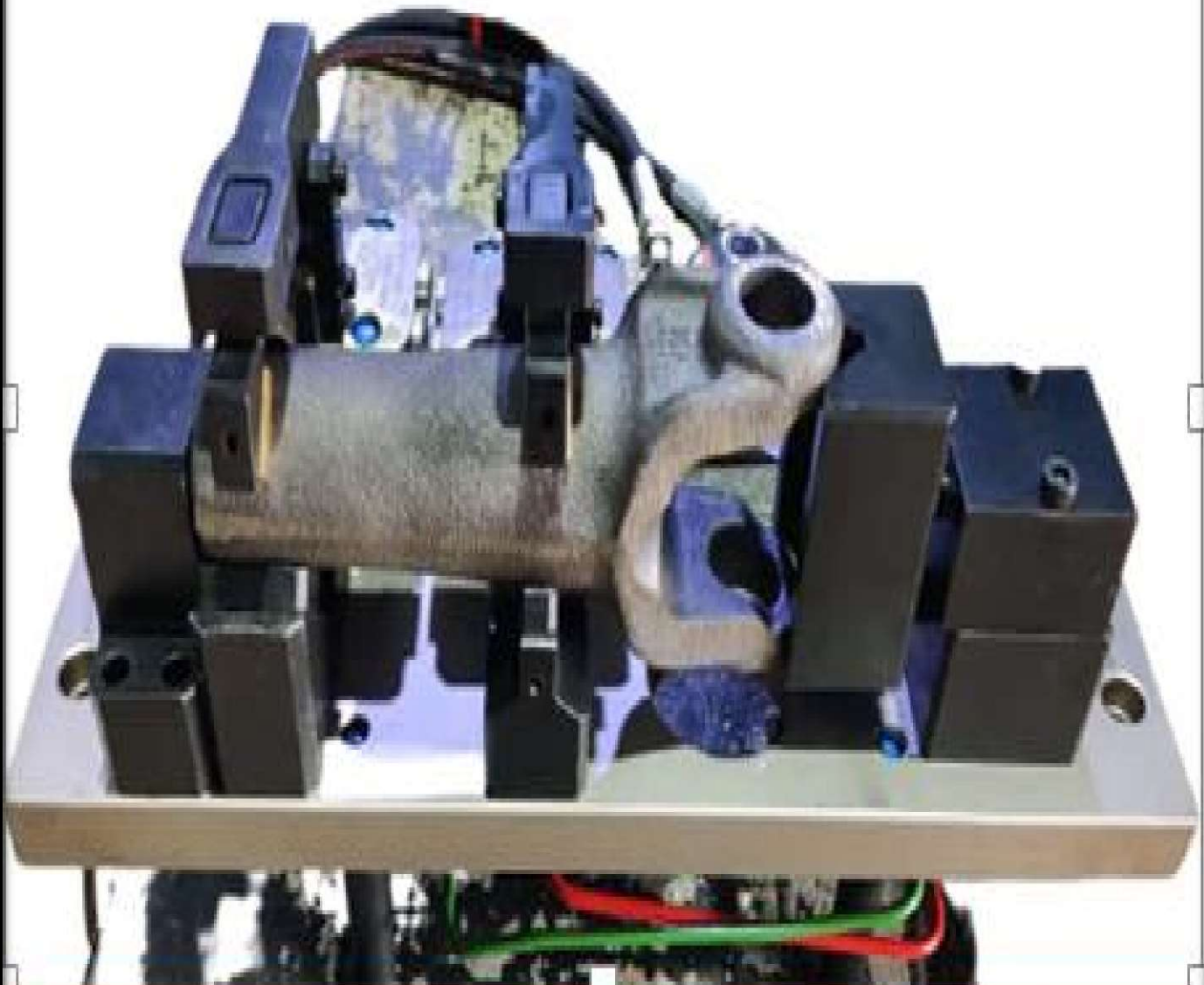



**! US HYDRAULICS !**



**MACHINE NAME : HMC MAKINO-A71**

**FIXTURE NAME : OP-30 HMC HYDRAULICS FIXTURE  
SPRING SIDE ALL OPERATIONS FIISH**

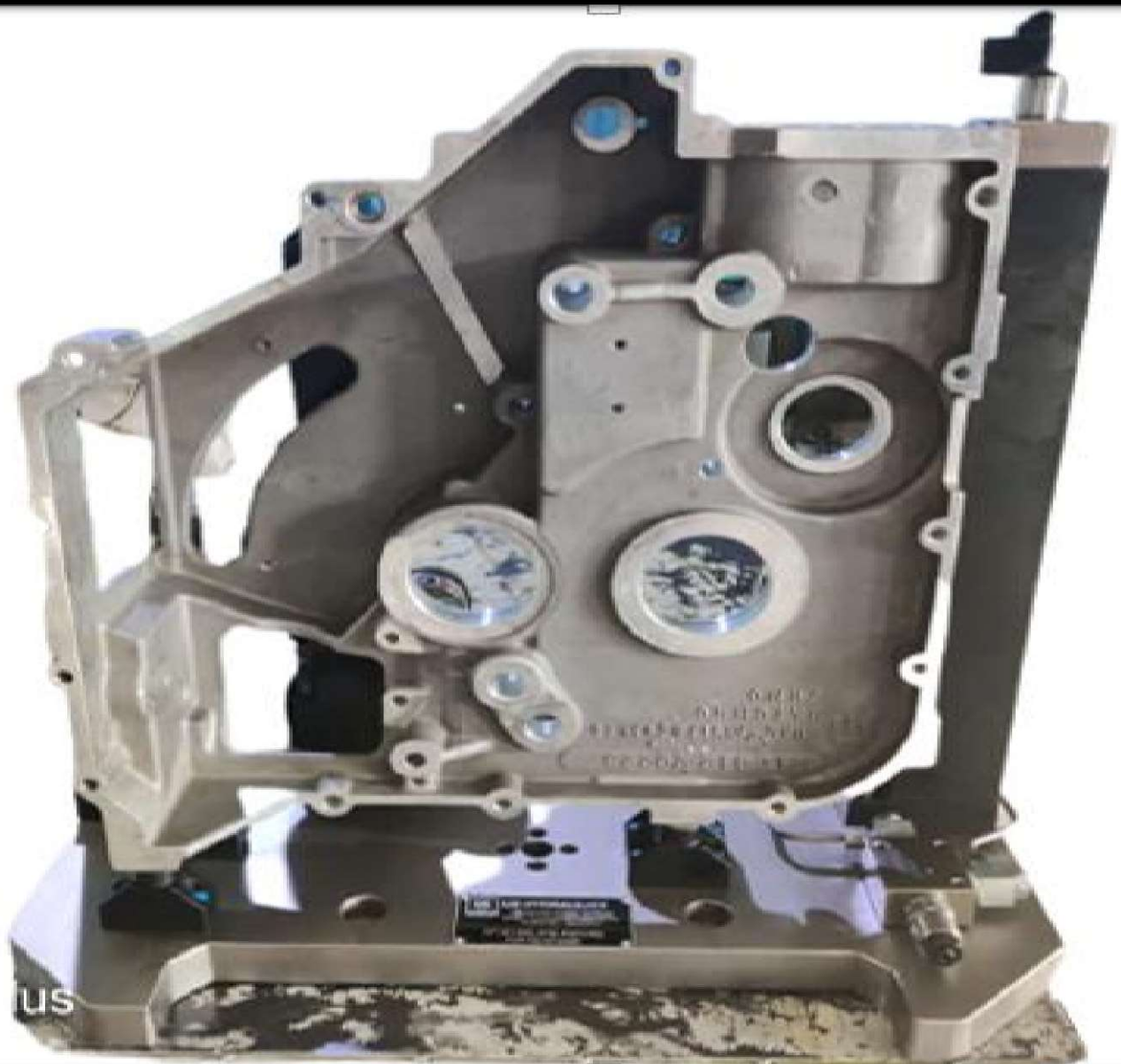

**! US HYDRAULICS !**



**MACHINE NAME : CNC TURNING**

**FIXTURE NAME : OP-10 CNC TURNING FIXTURE FOR HEAD-550**





**! US HYDRAULICS !**



**MACHINE NAME : AMS 850**

**FIXTURE NAME : OP-10 OP-20 VMC ROTARYHYD FIXTURE  
FOR HEAD FULE FILTER**

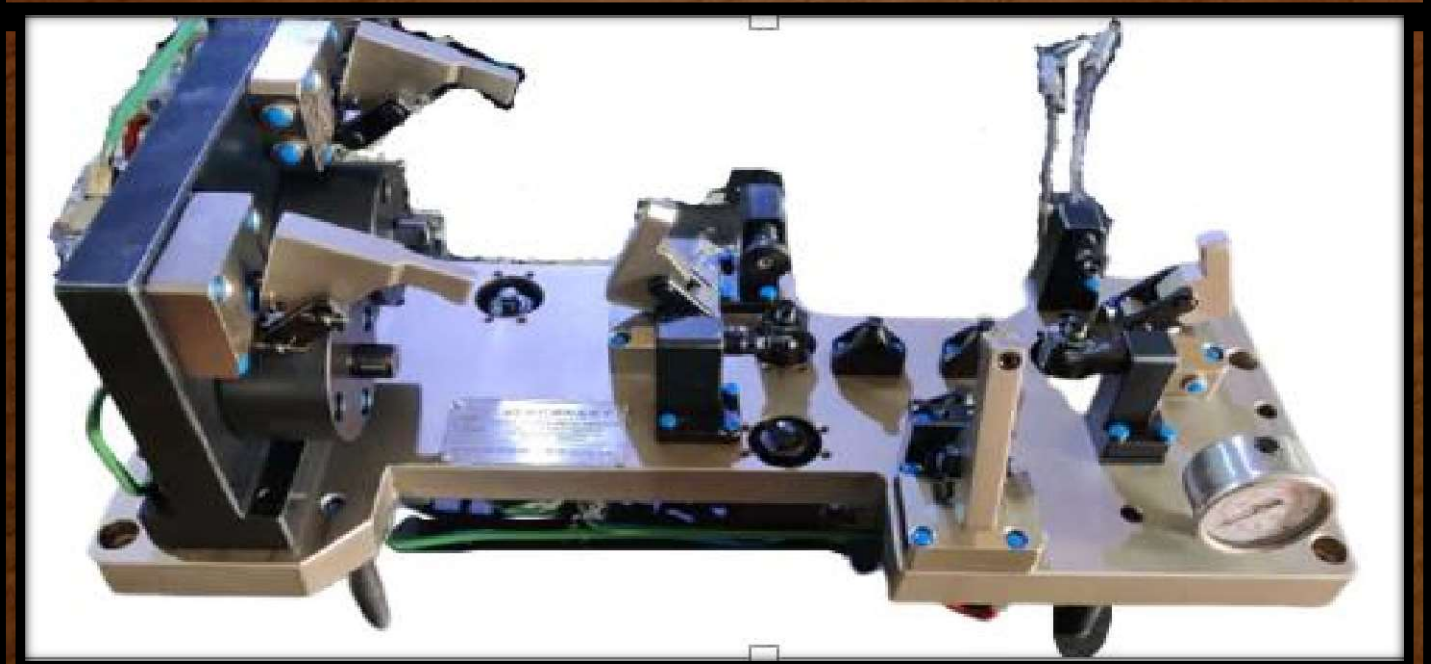
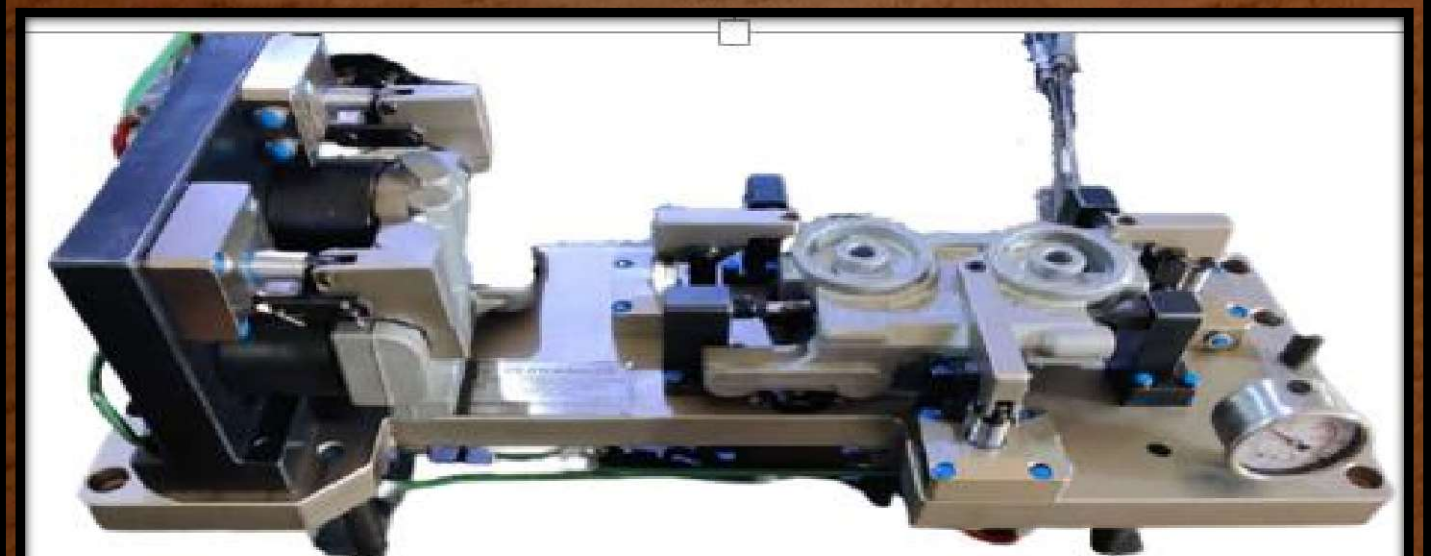

**! US HYDRAULICS !**



**MACHINE NAME : JOTIRDX-20**

**FIXTURE NAME : VOP-10 OP-20 VM ROTARYHYD FIXTURE  
FOR KTM CYL HEAD**





**! US HYDRAULICS !**



**MACHINE NAME : AMS740 PALLET CHANGE**

**FIXTURE NAME : OP-20 VMC ROTARYHYD FIXTURE FOR  
OUTPUT GEAR**

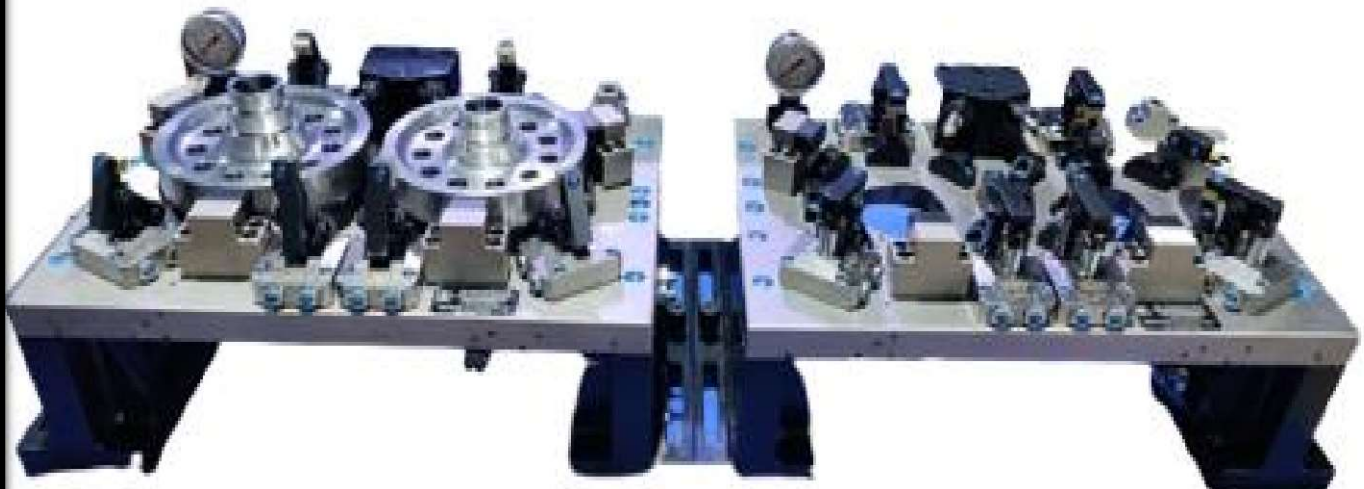



**! US HYDRAULICS !**



**MACHINE NAME : BROTHER**

**FIXTURE NAME : BROTHER CRADLE UIT**

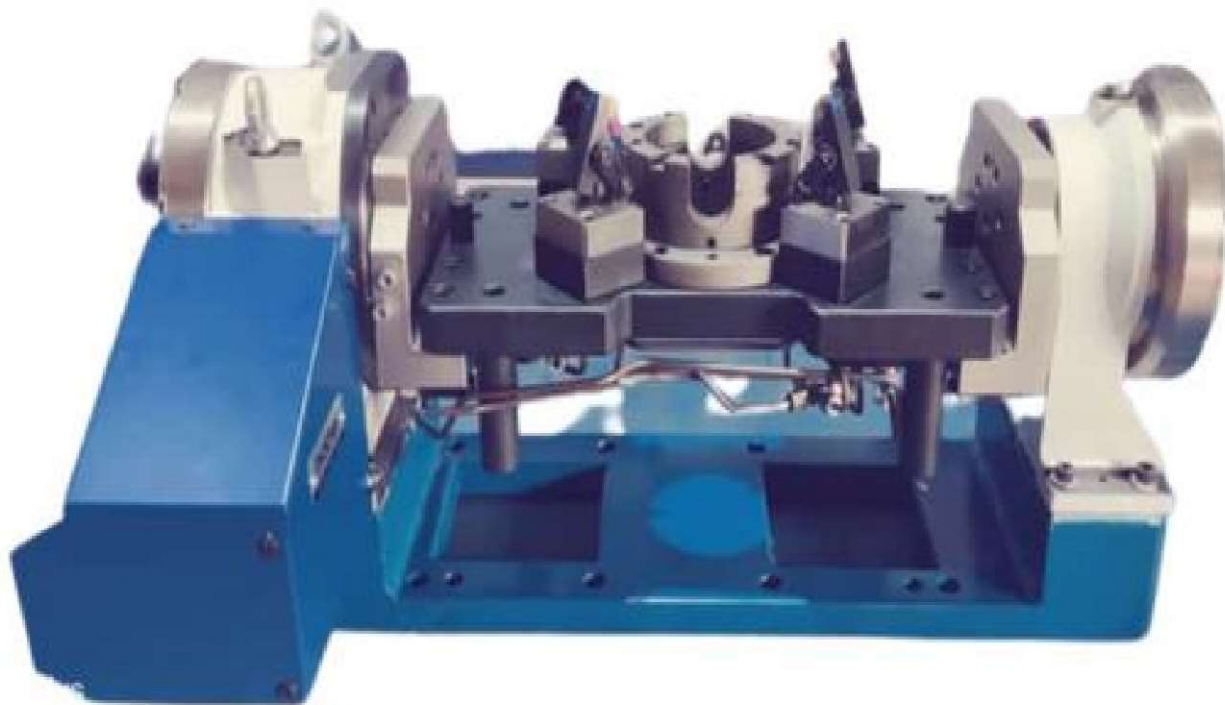

**! US HYDRAULICS !**



**MACHINE NAME :BFW BMV-50**

**FIXTURE NAME : VMC ROTARYHYD FIXTURE FOR FMTD54**

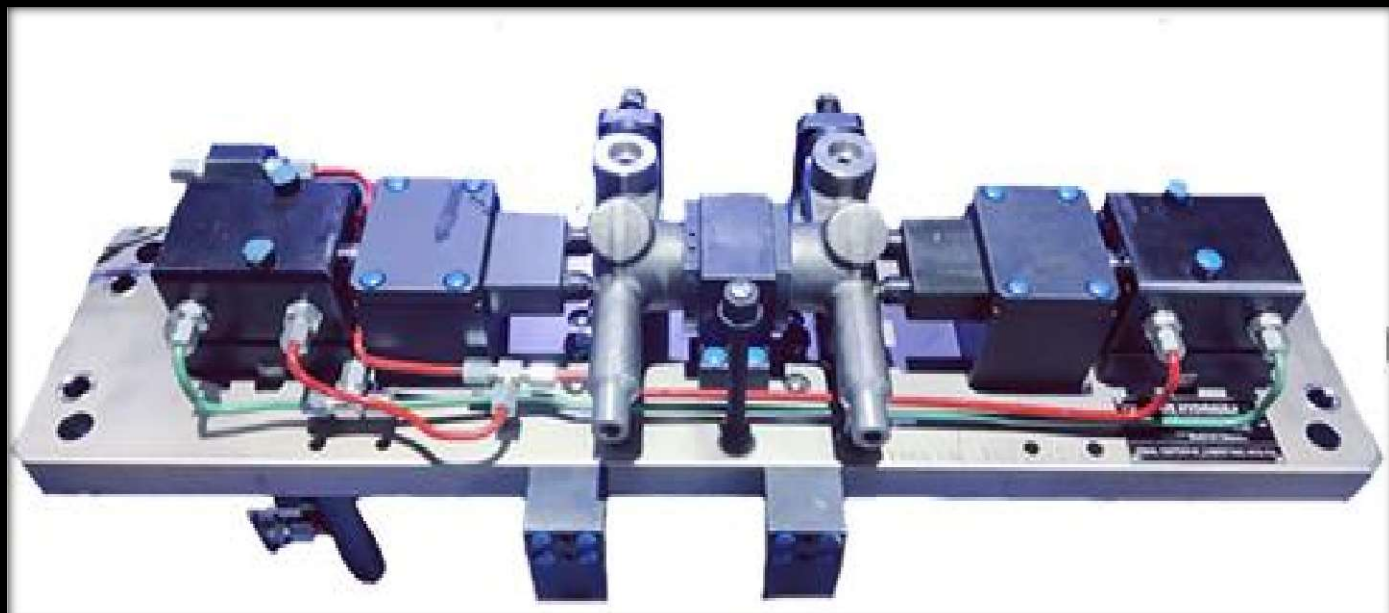
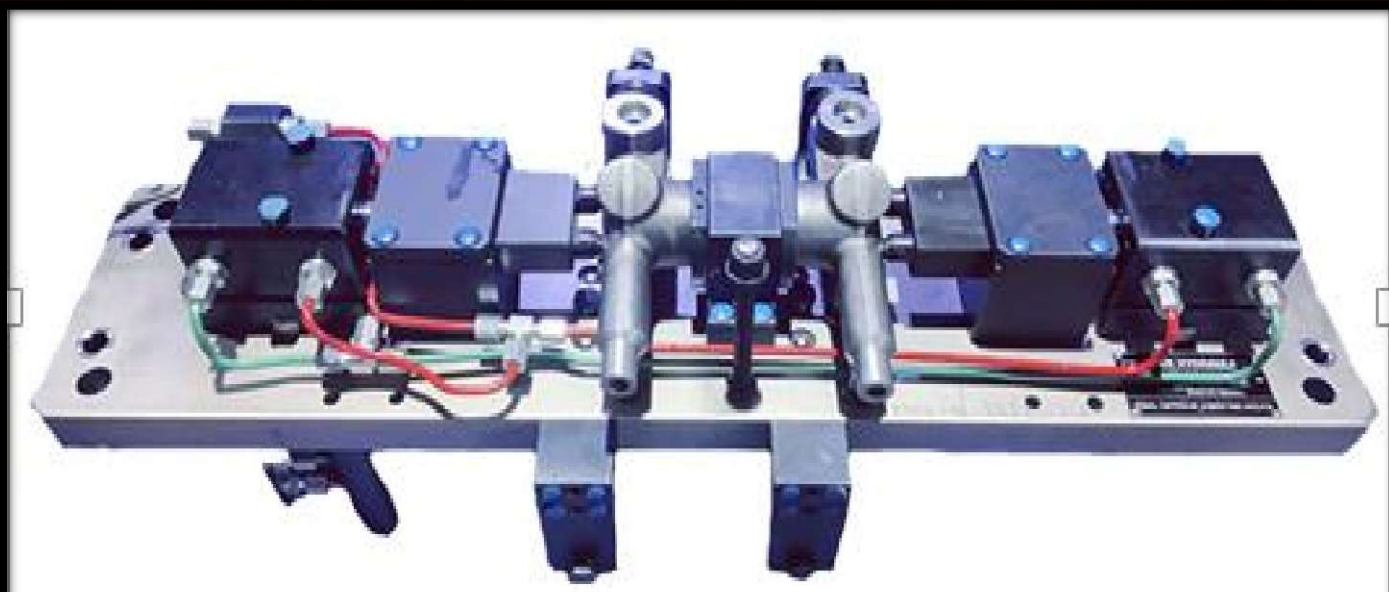



**! US HYDRAULICS !**



**MACHINE NAME : BROTHER**

**FIXTURE NAME : OP-20 VMC ROTARYHYD FIXTURE FOR  
MARUTI DIFFCASE**

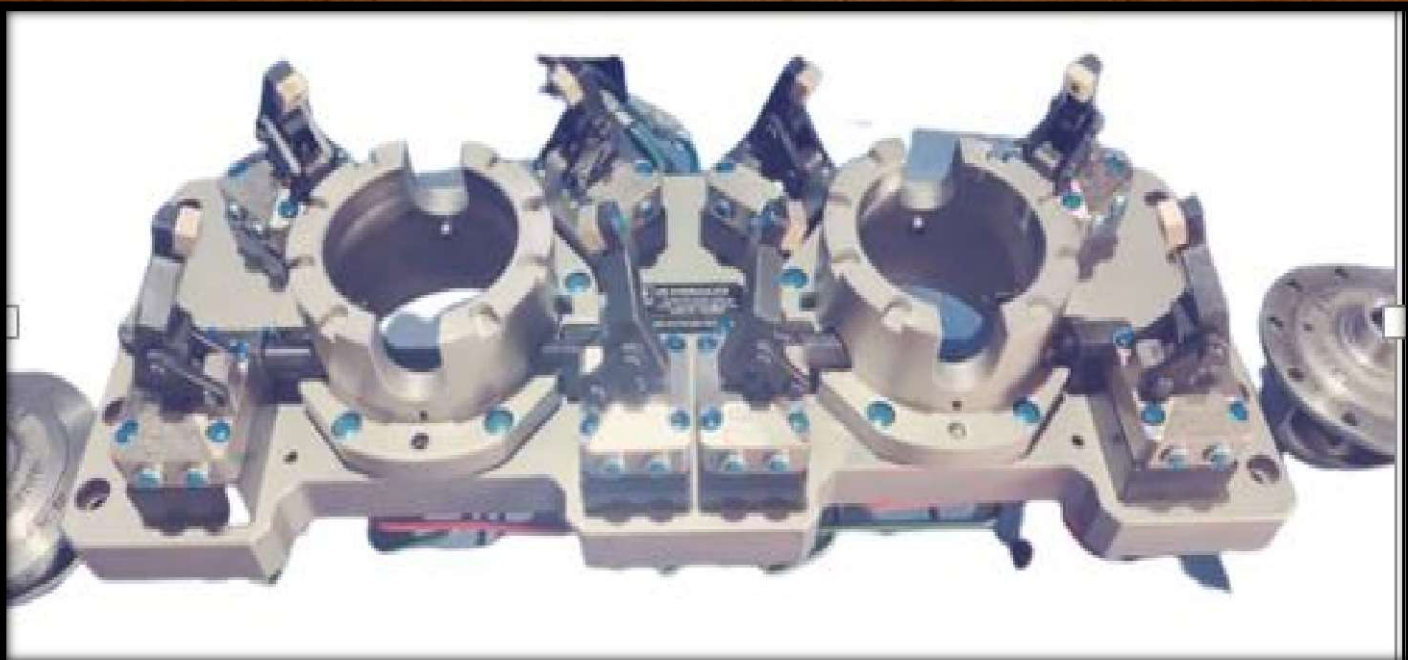

**! US HYDRAULICS !**



**MACHINE NAME : BFWBMV-50**

**FIXTURE NAME : OP-10 OP-20 VMC ROTARYHYD FIXTURE  
FOR OIL LUBE FILTER**

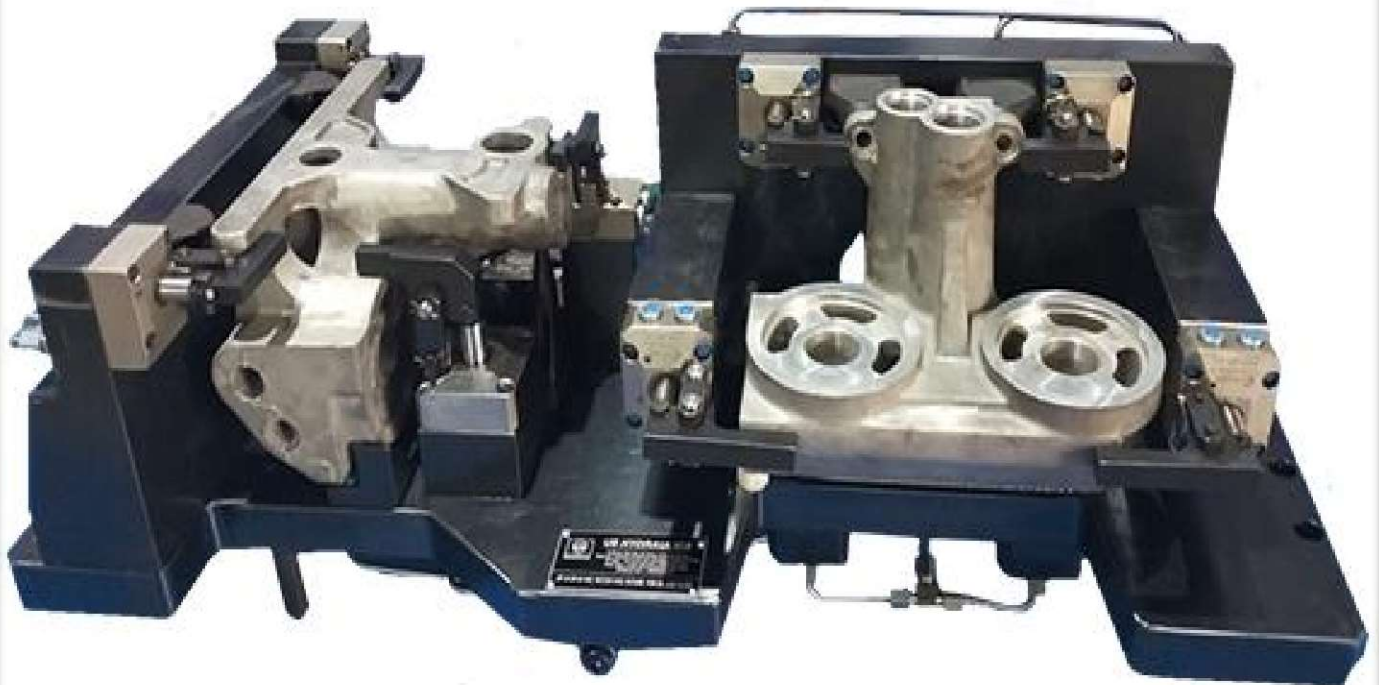



**! US HYDRAULICS !**



**MACHINE NAME : MAZZK 5<sup>TH</sup> AXIS**

**FIXTURE NAME : OP-40 5<sup>TH</sup> AXIS VMC HYD FIXTURE FOR P-702 DIFF CASE**



**! US HYDRAULICS !**



**MACHINE NAME : LMW**

**FIXTURE NAME : VMC HYD FIXTURE FOR MANIFOLD BLOCK**





**! US HYDRAULICS !**



**MACHINE NAME : BFW-BMV-60**

**FIXTURE NAME : ALL OPERATION FINISH VMC HYD FIXTURE  
FOR VALVE BODY**

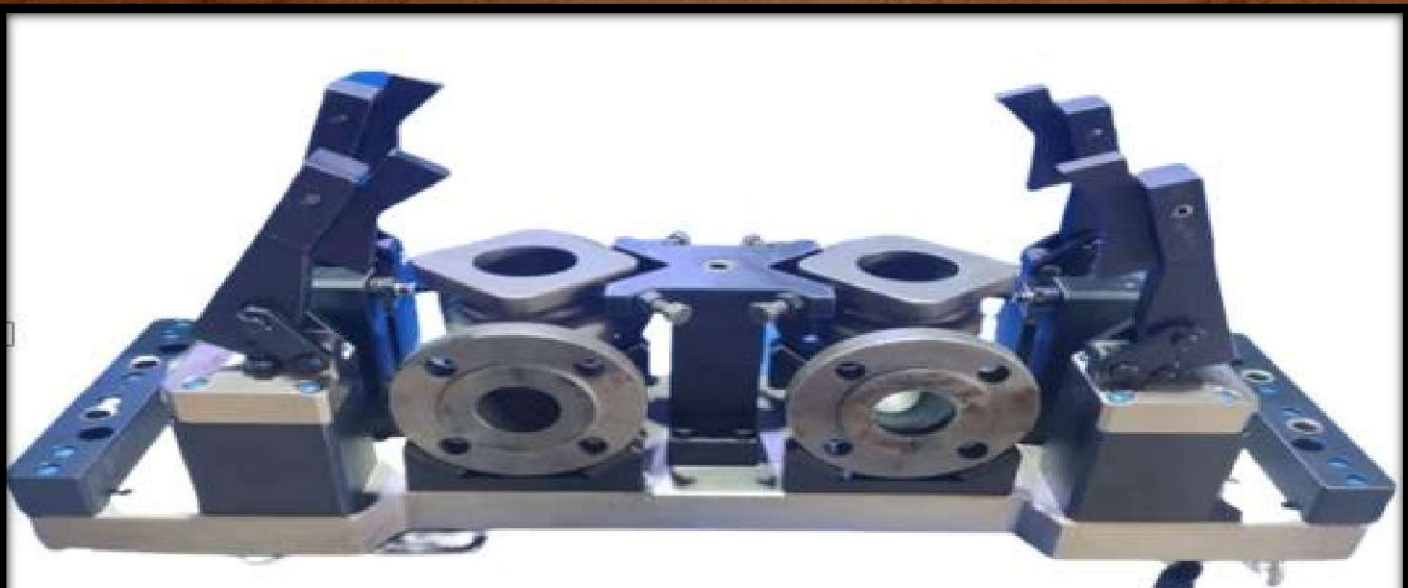



**! US HYDRAULICS !**



**MACHINE NAME : BFWBMV-60**

**FIXTURE NAME : ALL OPERATION FINISH VMC ROTARYHYD  
FIXTURE FOR VALVE BODY**

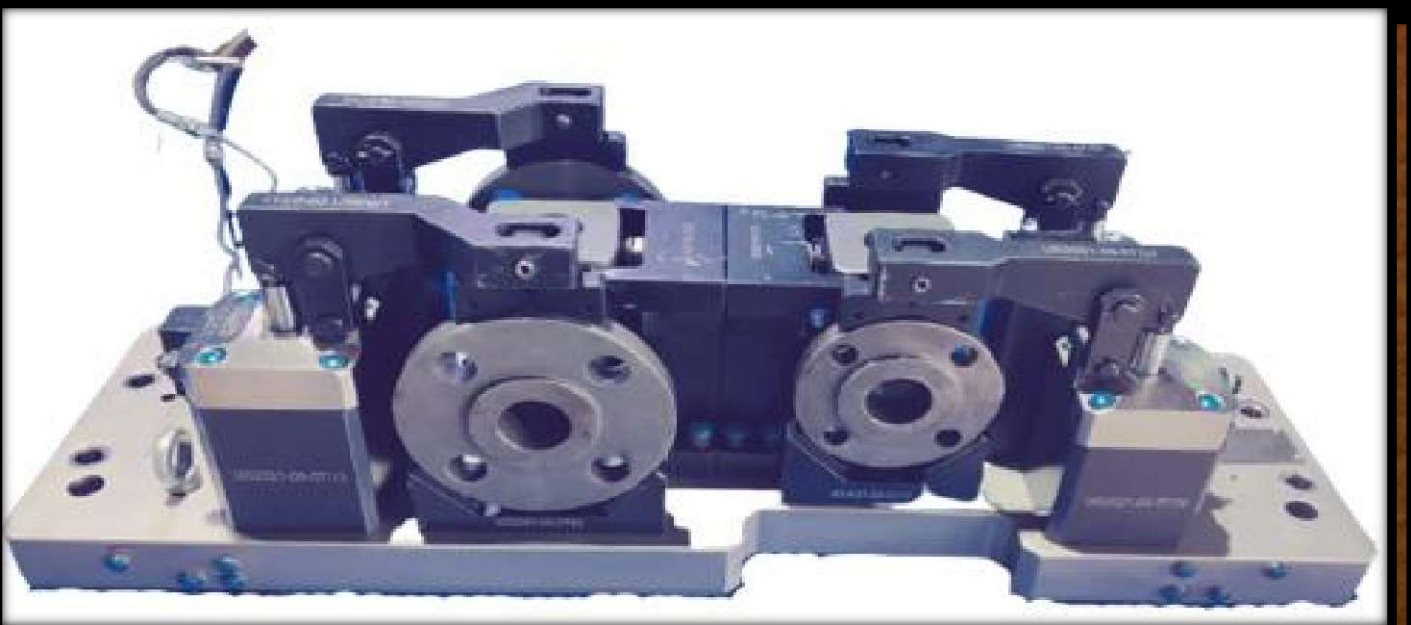

**! US HYDRAULICS !**



**MACHINE NAME : NIKKEN-260**

**FIXTURE NAME : NIKKEN 260 CRADLE UNIT**

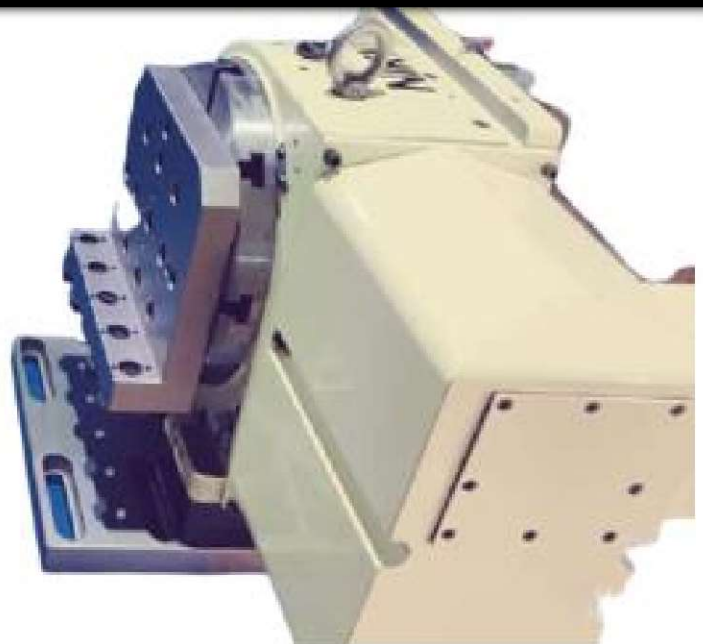
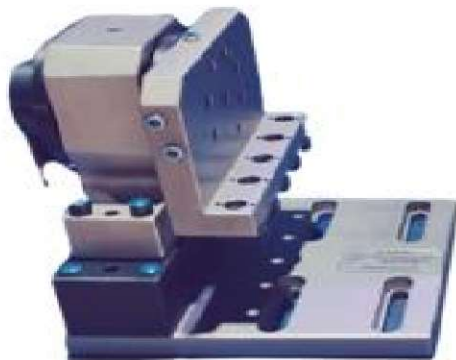



**! US HYDRAULICS !**



**MACHINE NAME : LOKESH**

**FIXTURE NAME : ALL OPERATION FINISH VMC ROTARYHYD  
FIXTURE FOR 4S CYLINDER BLOCK**

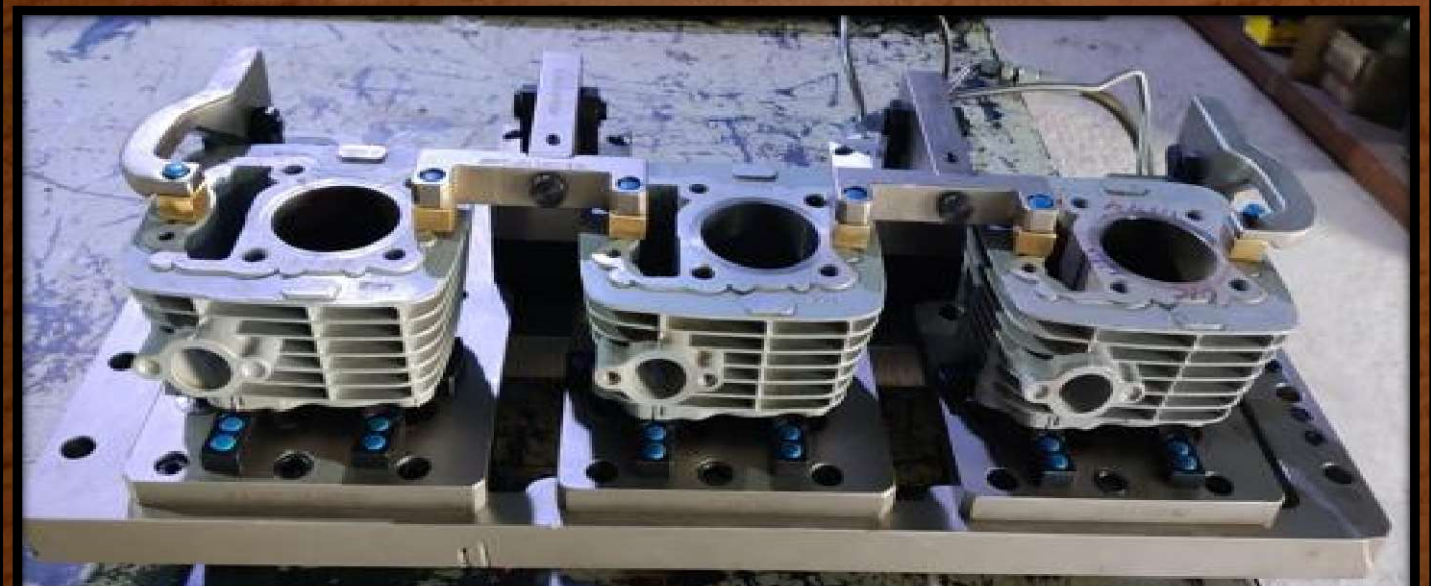



**! US HYDRAULICS !**



**MACHINE NAME : MAKINO-A81**

**FIXTURE NAME : OP-10 HMC HYD FIXTURE FOR MOTOR  
ROTER POLL**

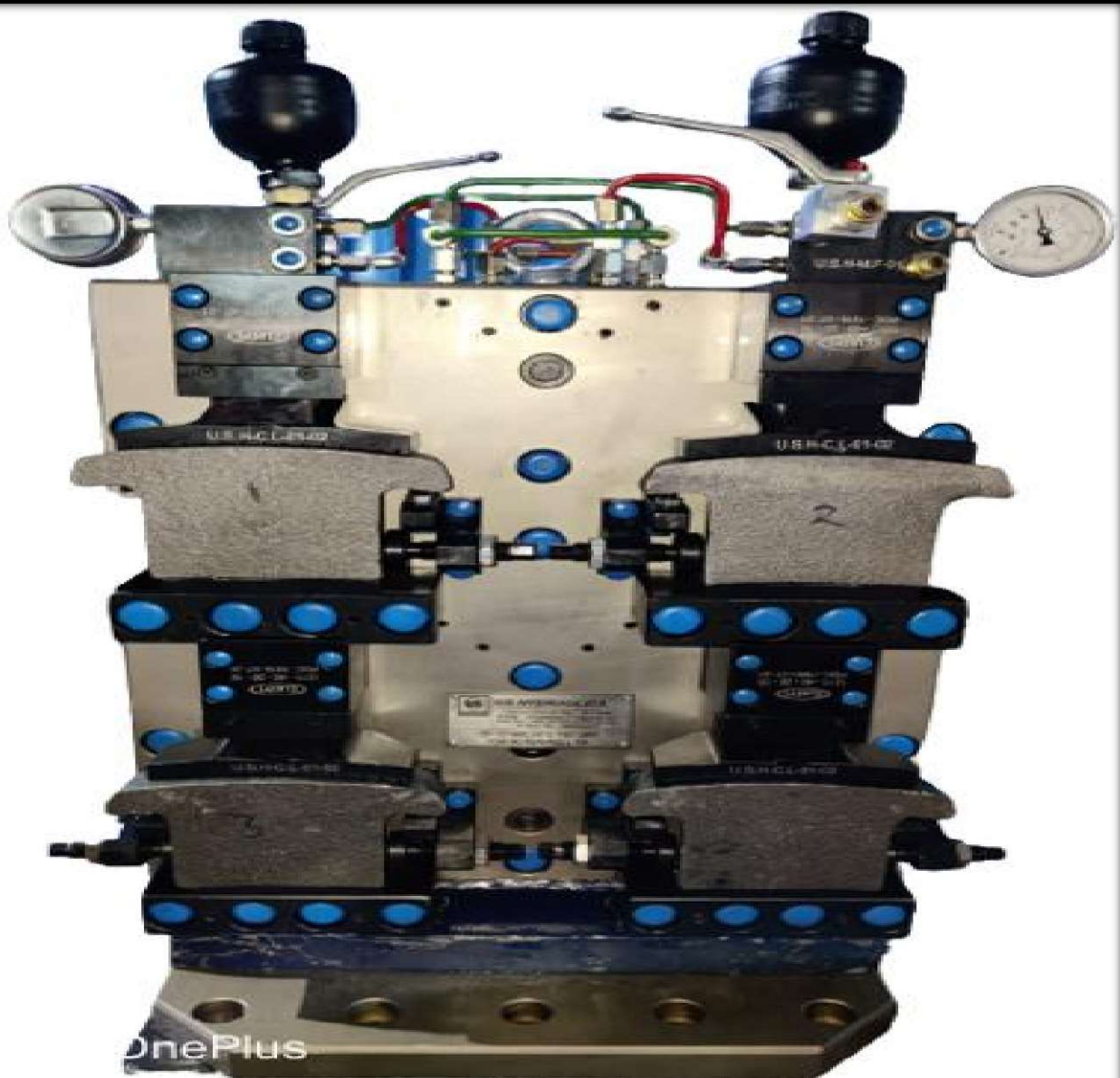

**! US HYDRAULICS !**



**MACHINE NAME : JOTIRDX-20**

**FIXTURE NAME : OP-10 OP-20 VMC ROTARY HYD FIXTUE  
FOR ETON MANFOLD BLOCK**





**! US HYDRAULICS !**



**MACHINE NAME : LMWTURMILL CENTER**

**FIXTURE NAME : OP-10 VMC TURNMILL FIXTURE FOR P-702 (MTHUBL)**





**! US HYDRAULICS !**

**MACHINE NAME : LMW-**

**FIXTURE NAME : OP-20 OP-30 VMC HYD FIXTUE FOR P-702  
HOUSING LH**

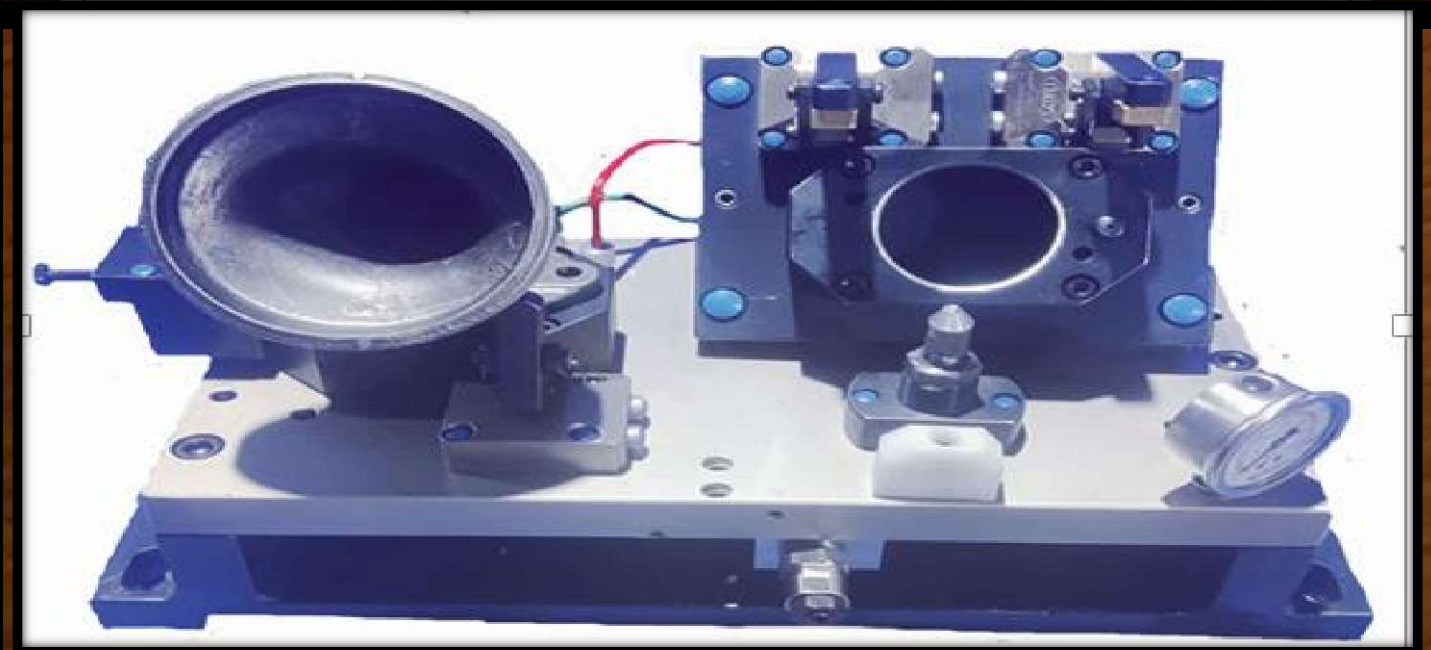
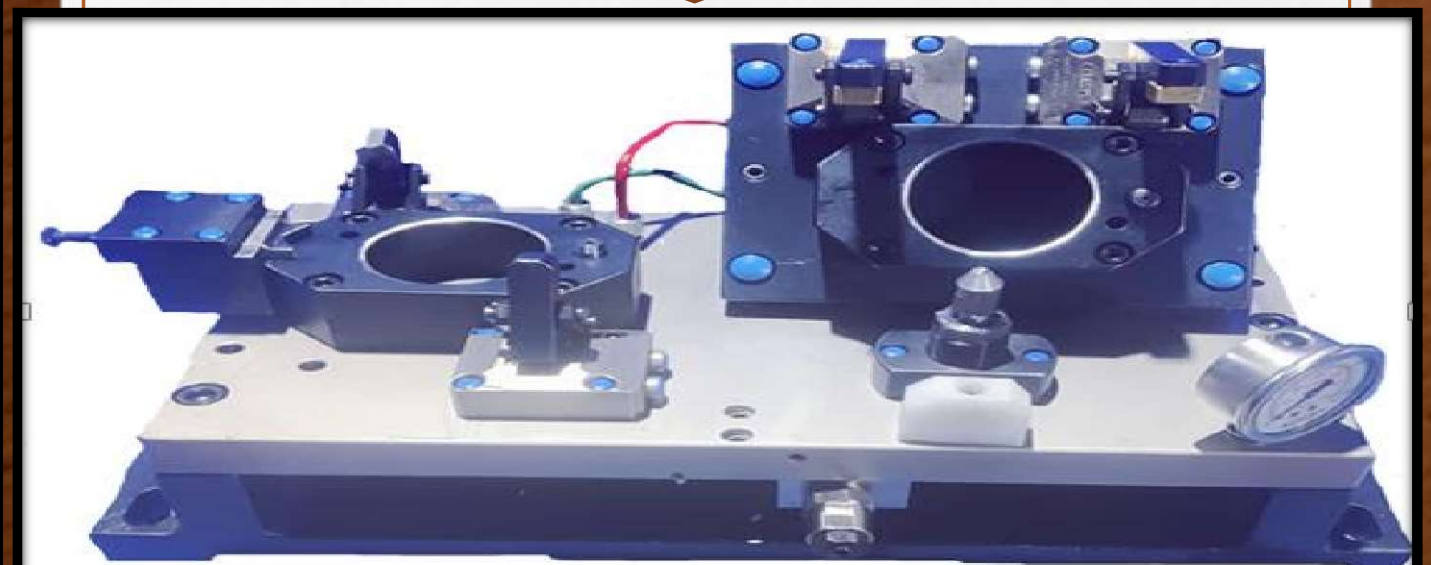

**! US HYDRAULICS !**



**MACHINE NAME : LMWCNC TURNING**

**FIXTURE NAME : OP-40 CNC TURNING FIXTURE FOR P-702**



**! US HYDRAULICS !**



**MACHINE NAME : STM 1060**

**FIXTURE NAME : VMC HYDFIXTURE FOR PROFILE PLAT 10  
COMPONENT LOADING**

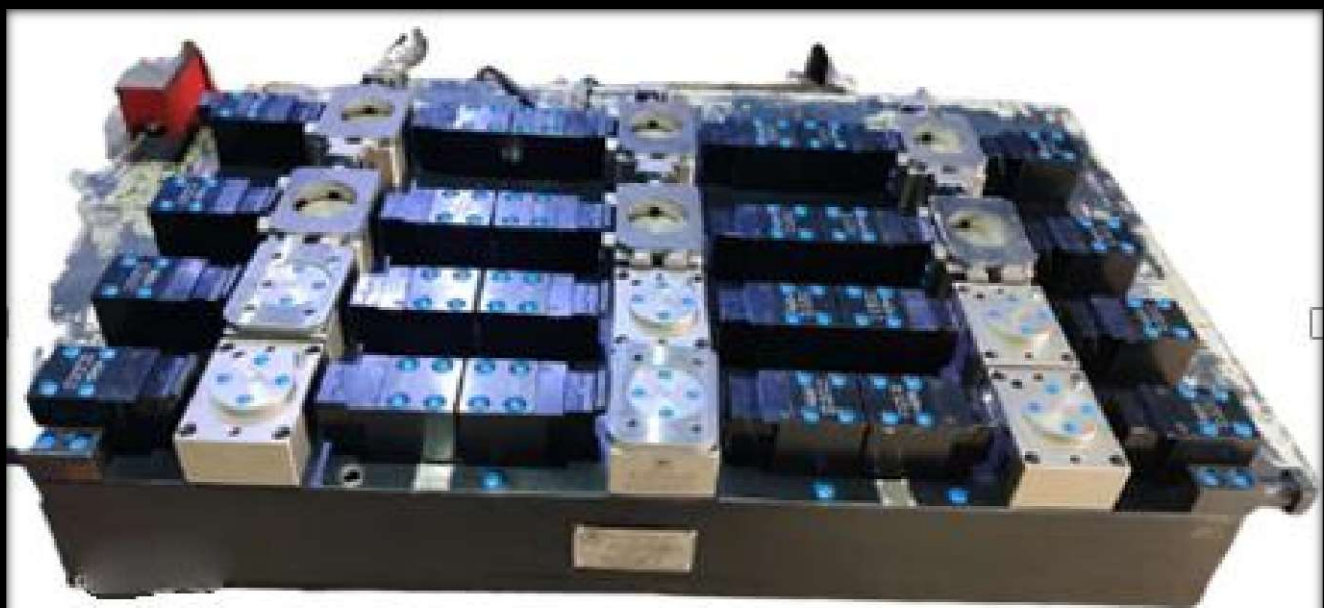



**! US HYDRAULICS !**



**HYDRAULIC POWER PACK**

**SINGLE STATION , DOUBLE STATION & 3 STATION**



! US HYDRAULICS !



MACHINE NAME SPM MACHINE

BUSH PRESS MACHINE





**! US HYDRAULICS !**



**MACHINE NAME:- SPM MACHINE**

**OIL REMOVAL MACHINE**



# PROTOTYPE COMPONENT

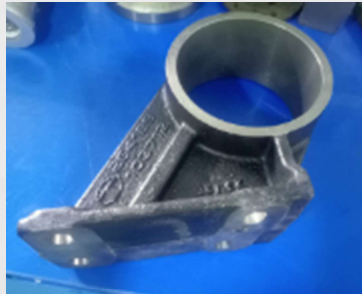



# US HYD PLANT..



USHYD....

